



UTILITY PUMPS



LUBRICATING OIL TRANSFER

40-size UTILITY PUMP with 1" ports and DC electric motor

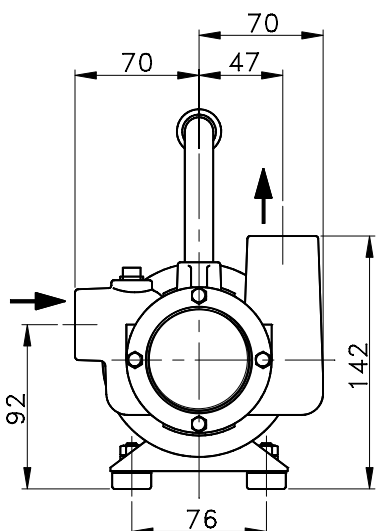
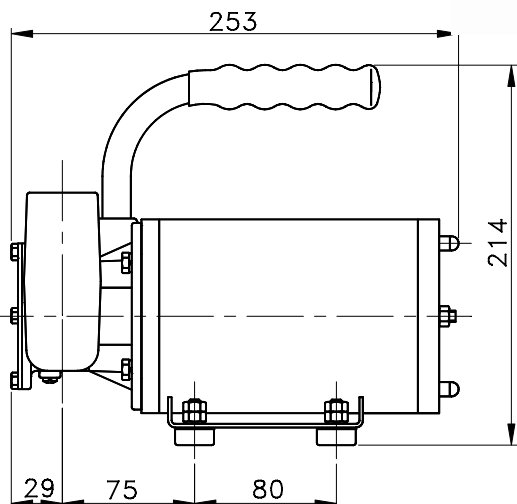

PORTS
1" BSP
internal
threaded

Dimensions
in mm

PUMP MODEL

53041-2053-24D 24 volt d.c.

◆ Nitrile oil-resistant impeller fitted as standard.

SPECIFICATION

Pump body: bronze

Weight: 9.5kg

Shaft: AIS316 stainless steel

Shaft seal: mechanical (carbon-ceramic)

Impeller: see pump models above

Max. recommended liquid viscosity: 1000cSt.

Check with your pump supplier if in doubt.

Motor:

0.25kw, totally enclosed, full load current 17 amps, IP54 enclosure

- ◆ Rapid self-priming up to 3 metres vertical lift
- ◆ Handles hard and soft solids up to 4mm in size
- ◆ Can pump up to 90% entrained air
- ◆ Up to 30 minutes dry running protection
- ◆ Quick and simple to maintain
- ◆ Light, compact, portable and tough
- ◆ Also available: Higher flow versions for liquid viscosity up to 150 cStokes. Check with your pump supplier.

PUMP PERFORMANCE

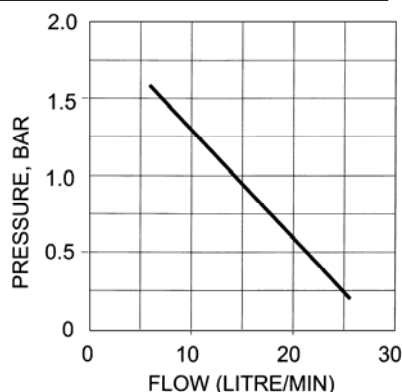

WARNING

Explosive hazard. Do not pump gasoline, solvents, thinners, or other flammable liquids. To do so can cause an explosion resulting in injury or death

Performance figures are based on manufacturer's tests with warm lubricating oil and are not guaranteed for any particular application.

Product descriptions and specifications are subject to alteration without notice



RELIABILITY WITH TOP QUALITY PUMP ENGINEERING
- FROM THE UK'S LEADING JABSCO SPECIALIST